



Typ SAW-830

modular @ analyse

Retractable holder made of high grade steel for hygienic installations from sensors with \varnothing 12 mm tanks and pipes

Advanced Features

- ▶ For all kind of 12/225 mm or \varnothing 12/280 with thread PG13,5 (pH-, Glas-, ISFET-, CO₂-, Redox- and other sensors)
- ▶ Food industry
- ▶ Pharmaceutical industry
- ▶ Requirement of automated sensor cleaning or calibration

Technical Features

- ▶ Hygienic design, EHEDG- / 3A approved process connections
- ▶ Automatic safety lock while sensor is removed
- ▶ Plug & Play installation, colour- and size-coded connection system
- ▶ Integrated limit switches
- ▶ AISI 316L / 1.4404, surface finish Ra<0,8, electropolished
- ▶ High variation of process connections
- ▶ Up to 16 bar and 140°C
- ▶ Drive unit free of maintenance
- ▶ Mechanical / pneumatic

Special Features

- Short lifting of only 36mm
- No problem with adhesive media
- No problem with o-ring abrasion

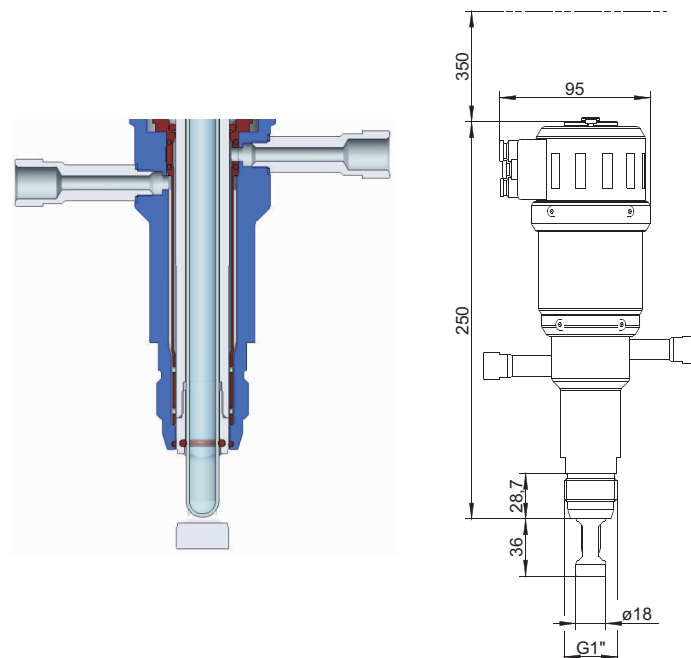



Typ SAW-830

modular @ analyse

Order Code

	SAW- 830-	4404	-		-		-	SE10	-		-	
Material (wettet parts)		4404										
High grade steel 1.4404 / 316L - surface < Ra0,8		4404										
Sealing Material (wettet parts)												
EPDM / FDA								EPD				
FPM (Viton)								FPM				
Sensor-type												
225 mm PG 13,5 für gel-filled										225		
280 mm PG 13,5 für liquid-filled										280		
Process Connection												
Thread-Nozzle G1"										SE10		
Cleaning Connection												
G 1/8" thread female												G18
G 1/4" thread female												G14
Position / Feedback												
pneumatic / pneumatic												PNPN
manual / without												MA00

Accessories and Spareparts

Part.Nr.	Description
2-123-40-005	Sealing set (Wetted Part SAW EPDM/FDA)
2-123-41-005	Sealing set (Wetted Part SAW FPM (Viton))
2-075-03-001	Drive unit pneumatic - sensor 225
2-075-03-002	Drive unit pneumatic - Sensor 280
2-075-03-003	Drive unit manal - Sensor 225 [1]
2-075-03-004	Drive unit manal - Sensor 280 [1]
2-061-33-004	Insertion rod SAW 1.4404 / 316L
2-086-32-001	Set blind plug G1/8" 1.430/316 for cleaning chamber

[1] The manual drive unit is only orderable together with the insertion rod!

Certificate

Part.Nr.	Description
2-121-01-001	Certifikate EN10204-2.2 for surface finishing
2-121-01-002	Certifikate EN10204-3.1.B for material